

Features

- Glass Passivated Die Construction
- 500W Peak Pulse Power Dissipation
- 5.0V – 170V Standoff Voltage
- Uni- and Bi-Directional Versions Available
- Excellent Clamping Capability
- Fast Response Time
- Plastic Case Material has UL Flammability Classification Rating 94V-O

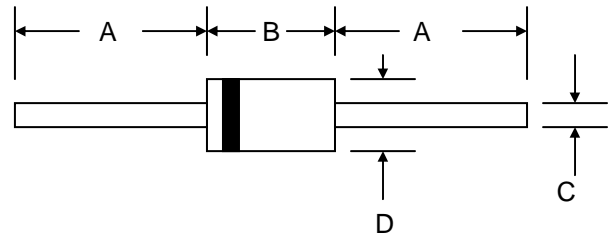

Mechanical Data

- Case: DO-15, Molded Plastic
- Terminals: Axial Leads, Solderable per MIL-STD-202, Method 208
- Polarity: Cathode Band Except Bi-Directional
- Marking: Type Number
- Weight: 0.40 grams (approx.)
- **Lead Free: For RoHS / Lead Free Version, Add "-LF" Suffix to Part Number, See Page 6**

DO-15		
Dim	Min	Max
A	25.4	—
B	5.50	7.62
C	0.71	0.864
D	2.60	3.60
All Dimensions in mm		

"C" Suffix Designates Bi-directional Devices
 "A" Suffix Designates 5% Tolerance Devices
 No Suffix Designates 10% Tolerance Devices

Maximum Ratings and Electrical Characteristics @ $T_A=25^\circ\text{C}$ unless otherwise specified

Characteristic	Symbol	Value	Unit
Peak Pulse Power Dissipation at $T_A = 25^\circ\text{C}$ (Note 1, 2, 5) Figure 3	PPPM	500 Minimum	W
Peak Forward Surge Current (Note 3)	IFSM	70	A
Peak Pulse Current on 10/1000 μs Waveform (Note 1) Figure 1	IPPM	See Table 1	A
Steady State Power Dissipation (Note 2, 4)	PM(AV)	3.0	W
Typical Thermal Resistance, Junction to Lead (Note 6)	$R_{\theta JL}$	33.3	$^\circ\text{C/W}$
Operating and Storage Temperature Range	T_j, T_{STG}	-65 to +175	$^\circ\text{C}$

- Note: 1. Non-repetitive current pulse per Figure 1 and derated above $T_A = 25^\circ\text{C}$ per Figure 4.
 2. Mounted on 40mm² copper pad.
 3. 8.3ms single half sine-wave duty cycle = 4 pulses per minutes maximum.
 4. Lead temperature at 75 $^\circ\text{C}$.
 5. Peak pulse power waveform is 10/1000 μs .
 6. Measured at lead length 3/8" (9.5mm) from body.

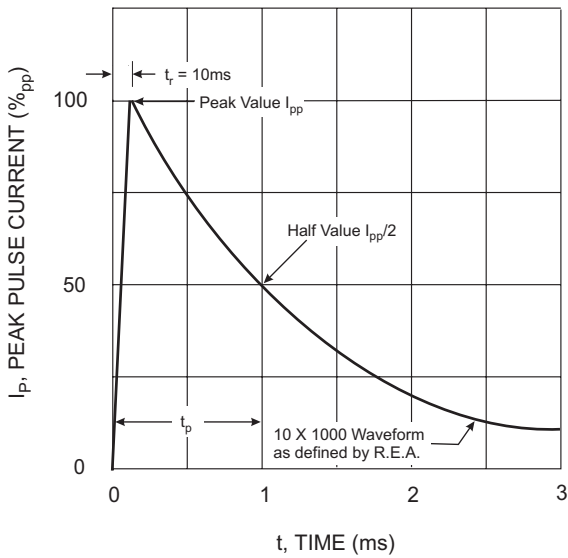

Fig. 1 Pulse Waveform

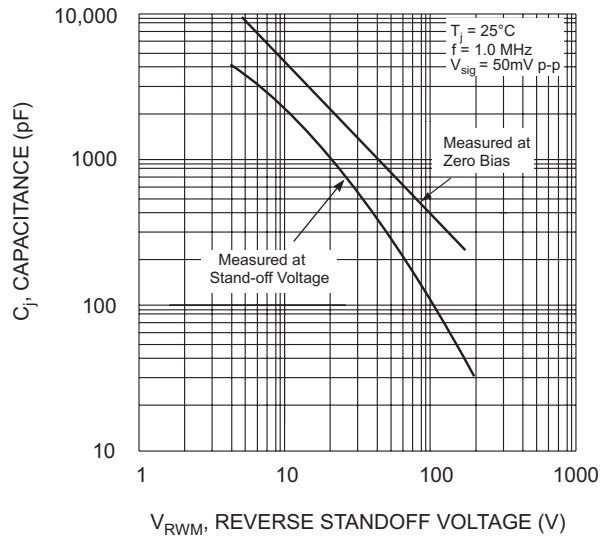

Fig. 2 Typical Junction Capacitance

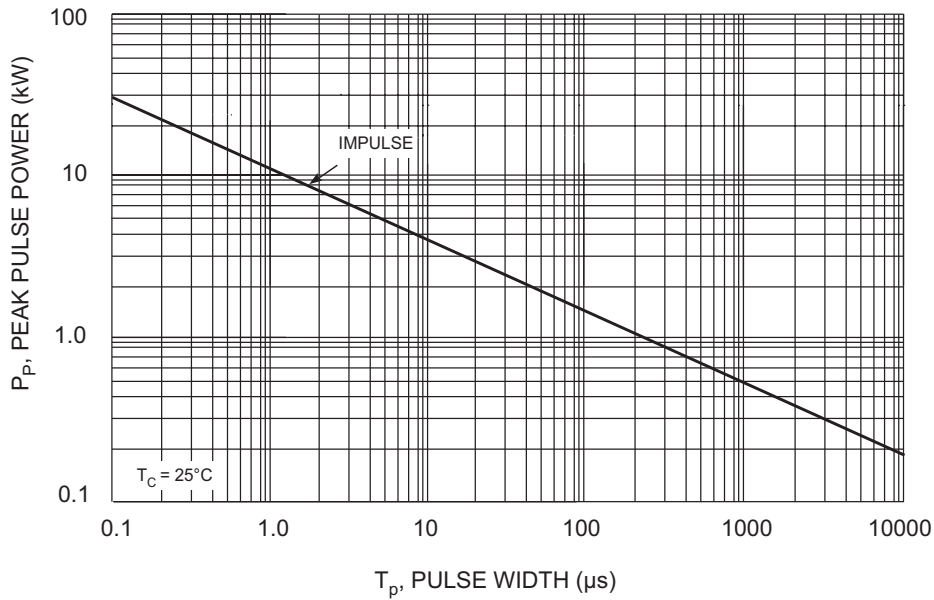

Fig. 3 Pulse Rating Curve

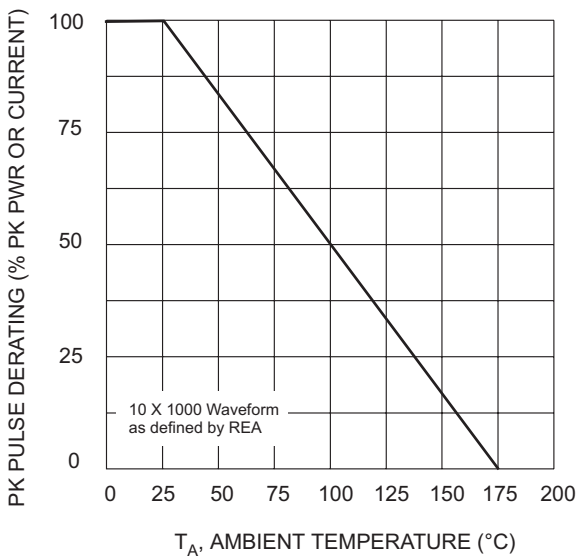

Fig. 4 Pulse Derating Curve

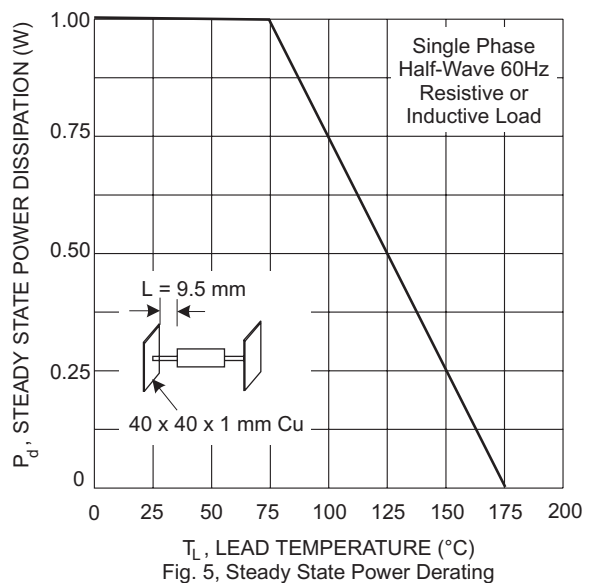

Fig. 5, Steady State Power Derating

UNI-DIRECTIONAL 500 WATT AXIAL LEAD TVS

UNI-DIRECTIONAL PART NUMBER	REVERSE STAND-OFF VOLTAGE VRWM (V)	BREAKDOWN VOLTAGE VBR (V) MIN. @IT	BREAKDOWN VOLTAGE VBR (V) MAX. @IT	TEST CURRENT IT (mA)	MAXIMUM CLAMPING VOLTAGE @Ipp Vc (V)	PEAK PULSE CURRENT Ipp (A)	REVERSE LEAKAGE @VRWM IR (uA)
SA5.0	5.00	6.40	7.55	10	9.6	52.3	600
SA5.0A	5.00	6.40	7.25	10	9.2	54.3	600
SA6.0	6.00	6.67	8.45	10	11.4	43.9	600
SA6.0A	6.00	6.67	7.67	10	10.3	48.5	600
SA6.5	6.50	7.22	9.14	10	12.3	40.7	400
SA6.5A	6.50	7.22	8.30	10	11.2	44.7	400
SA7.0	7.00	7.78	9.86	10	13.3	37.8	150
SA7.0A	7.00	7.78	8.95	10	12.0	41.7	150
SA7.5	7.50	8.33	10.67	1	14.3	35.0	50
SA7.5A	7.50	8.33	9.58	1	12.9	38.8	50
SA8.0	8.00	8.99	11.30	1	15.0	33.3	25
SA8.0A	8.00	8.99	10.23	1	13.6	36.7	25
SA8.5	8.50	9.44	11.92	1	15.9	31.4	10
SA8.5A	8.50	9.44	10.82	1	14.4	34.7	10
SA9.0	9.00	10.00	12.60	1	16.9	29.5	5
SA9.0A	9.00	10.00	11.50	1	15.4	32.5	5
SA10	10.00	11.10	14.10	1	18.8	26.6	1
SA10A	10.00	11.10	12.80	1	17.0	29.4	1
SA11	11.00	12.20	15.40	1	20.1	24.9	1
SA11A	11.00	12.20	14.00	1	18.2	27.4	1
SA12	12.00	13.30	16.90	1	22.0	22.7	1
SA12A	12.00	13.30	15.30	1	19.9	25.1	1
SA13	13.00	14.40	18.20	1	23.8	21.0	1
SA13A	13.00	14.40	16.50	1	21.5	23.2	1
SA14	14.00	15.60	19.80	1	25.8	19.4	1
SA14A	14.00	15.60	17.90	1	23.2	21.5	1
SA15	15.00	16.70	21.10	1	26.9	18.8	1
SA15A	15.00	16.70	19.20	1	24.4	20.6	1
SA16	16.00	17.80	22.60	1	28.8	17.6	1
SA16A	16.00	17.80	20.50	1	26.0	19.2	1
SA17	17.00	18.90	23.90	1	30.5	16.4	1
SA17A	17.00	18.90	21.70	1	27.6	16.1	1
SA18	18.00	20.00	25.30	1	32.2	15.5	1
SA18A	18.00	20.00	23.30	1	29.2	17.2	1
SA20	20.00	22.20	28.10	1	35.8	13.9	1
SA20A	20.00	22.20	25.50	1	32.4	15.4	1
SA22	22.00	24.40	30.90	1	39.4	12.7	1
SA22A	22.00	24.40	28.00	1	35.5	14.1	1
SA24	24.00	26.70	33.80	1	43.0	11.6	1
SA24A	24.00	26.70	30.70	1	38.9	12.8	1
SA26	26.00	28.90	36.60	1	46.6	10.7	1
SA26A	26.00	28.90	33.20	1	42.1	11.9	1
SA28	28.00	31.10	39.40	1	50.0	9.9	1
SA28A	28.00	31.10	35.80	1	45.4	11.0	1
SA30	30.00	33.30	42.20	1	53.5	9.3	1
SA30A	30.00	33.30	38.30	1	48.4	10.3	1
SA33	33.00	36.70	46.50	1	59.0	8.5	1
SA33A	33.00	36.70	42.20	1	53.3	9.4	1
SA36	36.00	40.00	50.70	1	64.3	7.8	1
SA36A	36.00	40.00	46.00	1	58.1	8.6	1
SA40	40.00	44.40	56.30	1	71.4	7.0	1
SA40A	40.00	44.40	51.10	1	64.5	7.8	1
SA43	43.00	47.80	60.50	1	76.7	6.5	1
SA43A	43.00	47.80	54.90	1	69.4	7.2	1
SA45	45.00	50.00	63.30	1	80.3	6.2	1
SA45A	45.00	50.00	57.50	1	72.7	6.9	1
SA48	48.00	53.30	67.50	1	85.5	5.8	1
SA48A	48.00	53.30	61.30	1	77.4	6.5	1
SA51	51.00	56.70	71.80	1	91.1	5.5	1
SA51A	51.00	56.70	65.20	1	82.4	6.1	1
SA54	54.00	60.00	76.00	1	96.3	5.2	1
SA54A	54.00	60.00	69.00	1	87.1	5.7	1
SA58	58.00	64.40	81.60	1	103.0	4.9	1
SA58A	58.00	64.40	74.10	1	93.6	5.3	1
SA60	60.00	66.70	84.50	1	107.0	4.7	1
SA60A	60.00	66.70	76.70	1	96.8	5.2	1
SA64	64.00	71.10	90.10	1	114.0	4.4	1
SA64A	64.00	71.10	81.80	1	103.0	4.9	1
SA70	70.00	77.80	98.60	1	125.0	4.0	1
SA70A	70.00	77.80	89.50	1	113.0	4.4	1
SA75	75.00	83.30	105.70	1	134.0	3.7	1
SA75A	75.00	83.30	95.80	1	121.0	4.1	1
SA78	78.00	86.70	109.80	1	139.0	3.6	1
SA78A	78.00	86.70	99.70	1	126.0	4.0	1
SA85	85.00	94.40	119.20	1	151.0	3.3	1
SA85A	85.00	94.40	108.20	1	137.0	3.6	1
SA90	90.00	100.00	126.50	1	160.0	3.1	1
SA90A	90.00	100.00	115.50	1	146.0	3.4	1
SA100	100.00	111.00	141.00	1	179.0	2.8	1
SA100A	100.00	111.00	128.00	1	162.0	3.1	1
SA110	110.00	122.00	154.50	1	196.0	2.6	1
SA110A	110.00	122.00	140.50	1	177.0	2.8	1
SA120	120.00	133.00	169.00	1	214.0	2.3	1
SA120A	120.00	133.00	153.00	1	193.0	2.0	1
SA130	130.00	144.00	182.50	1	231.0	2.2	1
SA130A	130.00	144.00	165.50	1	209.0	2.4	1
SA150	150.00	167.00	211.50	1	268.0	1.9	1
SA150A	150.00	167.00	192.50	1	243.0	2.1	1
SA160	160.00	178.00	226.00	1	287.0	1.7	1
SA160A	160.00	178.00	205.00	1	259.0	1.9	1
SA170	170.00	189.00	239.50	1	304.0	1.6	1
SA170A	170.00	189.00	217.50	1	275.0	1.8	1

BI-DIRECTIONAL 500 WATT AXIAL LEAD TVS

BI-DIRECTIONAL PART NUMBER	REVERSE STAND-OFF VOLTAGE VRWM (V)	BREAKDOWN VOLTAGE VBR (V) MIN. @IT	BREAKDOWN VOLTAGE VBR (V) MAX. @IT	TEST CURRENT IT (mA)	MAXIMUM CLAMPING VOLTAGE @Ipp Vc (V)	PEAK PULSE CURRENT Ipp (A)	REVERSE LEAKAGE @VRWM IR (uA)
SA5.0C	5.00	6.40	7.55	10	9.6	52.3	1200
SA5.0CA	5.00	6.40	7.25	10	9.2	54.3	1200
SA6.0C	6.00	6.67	8.45	10	11.4	43.9	1200
SA6.0CA	6.00	6.67	7.67	10	10.3	48.5	1200
SA6.5C	6.50	7.22	9.14	10	12.3	40.7	800
SA6.5CA	6.50	7.22	8.30	10	11.2	44.7	800
SA7.0C	7.00	7.78	9.86	10	13.3	37.8	300
SA7.0CA	7.00	7.78	8.95	10	12.0	41.7	300
SA7.5C	7.50	8.33	10.67	1	14.3	35.0	100
SA7.5CA	7.50	8.33	9.58	1	12.9	38.8	100
SA8.0C	8.00	8.99	11.30	1	15.0	33.3	50
SA8.0CA	8.00	8.99	10.23	1	13.6	36.7	50
SA8.5C	8.50	9.44	11.92	1	15.9	31.4	20
SA8.5CA	8.50	9.44	10.82	1	14.4	34.7	20
SA9.0C	9.00	10.00	12.60	1	16.9	29.5	5
SA9.0CA	9.00	10.00	11.50	1	15.4	32.5	5
SA10C	10.00	11.10	14.10	1	18.8	26.6	1
SA10CA	10.00	11.10	12.80	1	17.0	29.4	1
SA11C	11.00	12.20	15.40	1	20.1	24.9	1
SA11CA	11.00	12.20	14.00	1	18.2	27.4	1
SA12C	12.00	13.30	16.90	1	22.0	22.7	1
SA12CA	12.00	13.30	15.30	1	19.9	25.1	1
SA13C	13.00	14.40	18.20	1	23.8	21.0	1
SA13CA	13.00	14.40	16.50	1	21.5	23.2	1
SA14C	14.00	15.60	19.80	1	25.8	19.4	1
SA14CA	14.00	15.60	17.90	1	23.2	21.5	1
SA15C	15.00	16.70	21.10	1	26.9	18.8	1
SA15CA	15.00	16.70	19.20	1	24.4	20.6	1
SA16C	16.00	17.80	22.60	1	28.8	17.6	1
SA16CA	16.00	17.80	20.50	1	26.0	19.2	1
SA17C	17.00	18.90	23.90	1	30.5	16.4	1
SA17CA	17.00	18.90	21.70	1	27.6	16.1	1
SA18C	18.00	20.00	25.30	1	32.2	15.5	1
SA18CA	18.00	20.00	23.30	1	29.2	17.2	1
SA20C	20.00	22.20	28.10	1	35.8	13.9	1
SA20CA	20.00	22.20	25.50	1	32.4	15.4	1
SA22C	22.00	24.40	30.90	1	39.4	12.7	1
SA22CA	22.00	24.40	28.00	1	35.5	14.1	1
SA24C	24.00	26.70	33.80	1	43.0	11.6	1
SA24CA	24.00	26.70	30.70	1	38.9	12.8	1
SA26C	26.00	28.90	36.60	1	46.6	10.7	1
SA26CA	26.00	28.90	33.20	1	42.1	11.9	1
SA28C	28.00	31.10	39.40	1	50.0	9.9	1
SA28CA	28.00	31.10	35.80	1	45.4	11.0	1
SA30C	30.00	33.30	42.20	1	53.5	9.3	1
SA30CA	30.00	33.30	38.30	1	48.4	10.3	1
SA33C	33.00	36.70	46.50	1	59.0	8.5	1
SA33CA	33.00	36.70	42.20	1	53.3	9.4	1
SA36C	36.00	40.00	50.70	1	64.3	7.8	1
SA36CA	36.00	40.00	46.00	1	58.1	8.6	1
SA40C	40.00	44.40	56.30	1	71.4	7.0	1
SA40CA	40.00	44.40	51.10	1	64.5	7.8	1
SA43C	43.00	47.80	60.50	1	76.7	6.5	1
SA43CA	43.00	47.80	54.90	1	69.4	7.2	1
SA45C	45.00	50.00	63.30	1	80.3	6.2	1
SA45CA	45.00	50.00	57.50	1	72.7	6.9	1
SA48C	48.00	53.30	67.50	1	85.5	5.8	1
SA48CA	48.00	53.30	61.30	1	77.4	6.5	1
SA51C	51.00	56.70	71.80	1	91.1	5.5	1
SA51CA	51.00	56.70	65.20	1	82.4	6.1	1
SA54C	54.00	60.00	76.00	1	96.3	5.2	1
SA54CA	54.00	60.00	69.00	1	87.1	5.7	1
SA58C	58.00	64.40	81.60	1	103.0	4.9	1
SA58CA	58.00	64.40	74.10	1	93.6	5.3	1
SA60C	60.00	66.70	84.50	1	107.0	4.7	1
SA60CA	60.00	66.70	76.70	1	96.8	5.2	1
SA64C	64.00	71.10	90.10	1	114.0	4.4	1
SA64CA	64.00	71.10	81.80	1	103.0	4.9	1
SA70C	70.00	77.80	98.60	1	125.0	4.0	1
SA70CA	70.00	77.80	89.50	1	113.0	4.4	1
SA75C	75.00	83.30	105.70	1	134.0	3.7	1
SA75CA	75.00	83.30	95.80	1	121.0	4.1	1
SA78C	78.00	86.70	109.80	1	139.0	3.6	1
SA78CA	78.00	86.70	99.70	1	126.0	4.0	1
SA85C	85.00	94.40	119.20	1	151.0	3.3	1
SA85CA	85.00	94.40	108.20	1	137.0	3.6	1
SA90C	90.00	100.00	126.50	1	160.0	3.1	1
SA90CA	90.00	100.00	115.50	1	146.0	3.4	1
SA100C	100.00	111.00	141.00	1	179.0	2.8	1
SA100CA	100.00	111.00	128.00	1	162.0	3.1	1
SA110C	110.00	122.00	154.50	1	196.0	2.6	1
SA110CA	110.00	122.00	140.50	1	177.0	2.8	1
SA120C	120.00	133.00	169.00	1	214.0	2.3	1
SA120CA	120.00	133.00	153.00	1	193.0	2.0	1
SA130C	130.00	144.00	182.50	1	231.0	2.2	1
SA130CA	130.00	144.00	165.50	1	209.0	2.4	1
SA150C	150.00	167.00	211.50	1	268.0	1.9	1
SA150CA	150.00	167.00	192.50	1	243.0	2.1	1
SA160C	160.00	178.00	226.00	1	287.0	1.7	1
SA160CA	160.00	178.00	205.00	1	259.0	1.9	1
SA170C	170.00	189.00	239.50	1	304.0	1.6	1
SA170CA	170.00	189.00	217.50	1	275.0	1.8	1

MARKING INFORMATION

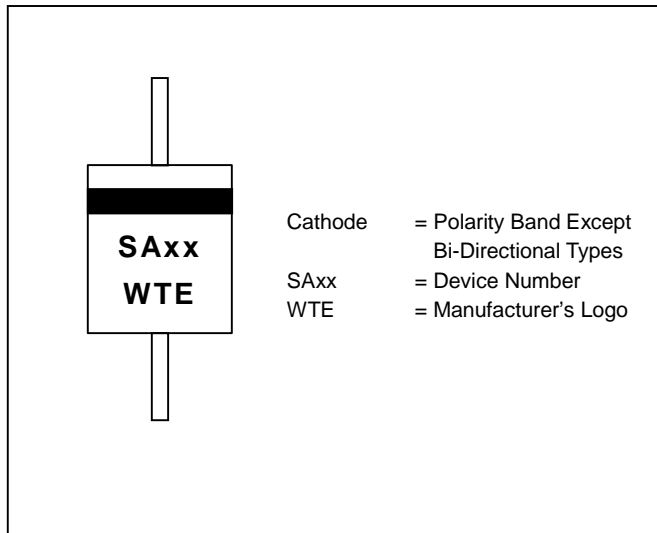

TAPING SPECIFICATIONS

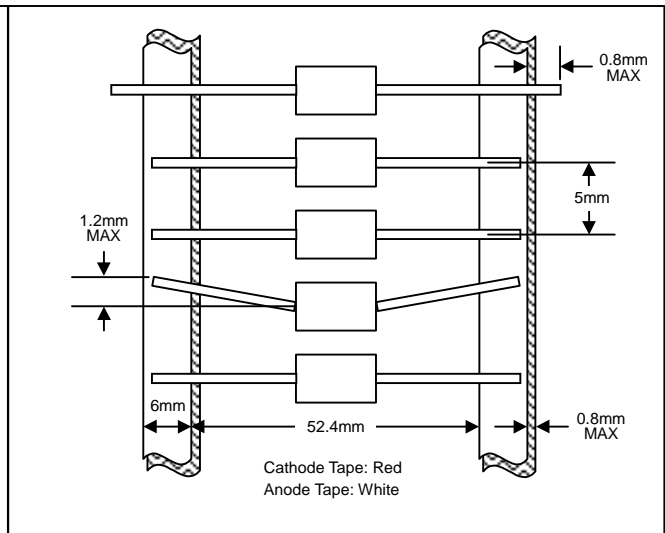

PACKAGING INFORMATION

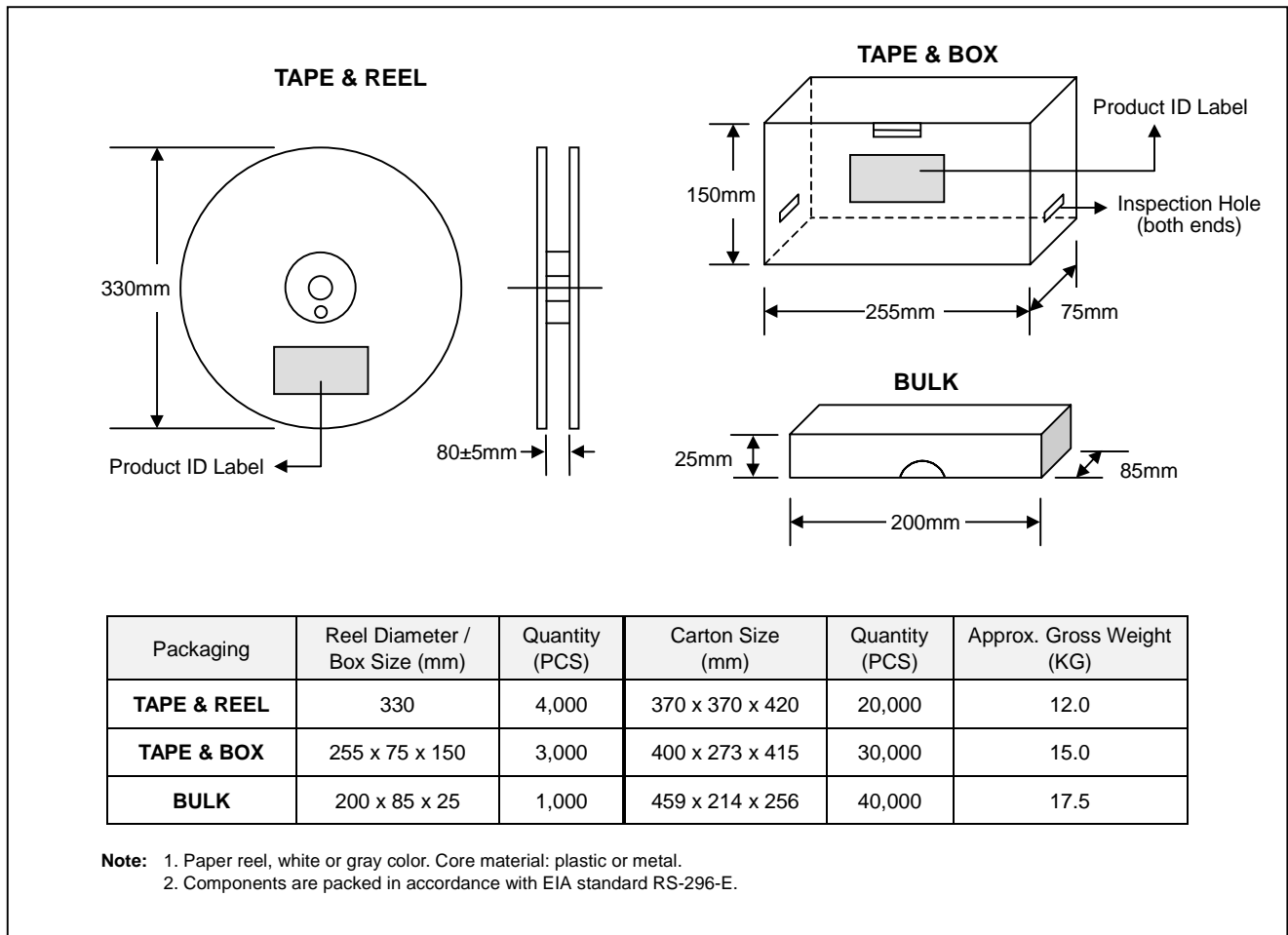

ORDERING INFORMATION

Product No.	Package Type	Shipping Quantity
SAxx-T3	DO-15	4000/Tape & Reel
SAxx-TB	DO-15	3000/Tape & Box
SAxx	DO-15	1000 Units/Box

1. Products listed in **bold** are WTE **Preferred** devices.
2. Shipping quantity given is for minimum packing quantity only. For minimum order quantity, please consult the Sales Department.
3. **To order RoHS / Lead Free version, add "-LF" suffix to part number above. For example, SA5.0-TB-LF.**

Won-Top Electronics Co., Ltd (WTE) has checked all information carefully and believes it to be correct and accurate. However, WTE cannot assume any responsibility for inaccuracies. Furthermore, this information does not give the purchaser of semiconductor devices any license under patent rights to manufacturer. WTE reserves the right to change any or all information herein without further notice.

WARNING: DO NOT USE IN LIFE SUPPORT EQUIPMENT. WTE power semiconductor products are not authorized for use as critical components in life support devices or systems without the express written approval.

Won-Top Electronics Co., Ltd.

No. 44 Yu Kang North 3rd Road, Chine Chen Dist., Kaohsiung, Taiwan

Phone: 886-7-822-5408 or 886-7-822-5410

Fax: 886-7-822-5417

Email: sales@wontop.com

Internet: <http://www.wontop.com>

We power your everyday.