

Features

- Glass Passivated Die Construction
- 600W Peak Pulse Power Dissipation
- 180V – 440V Standoff Voltage
- Uni- and Bi-Directional Versions Available
- Excellent Clamping Capability
- Fast Response Time
- Plastic Case Material has UL Flammability Classification Rating 94V-O

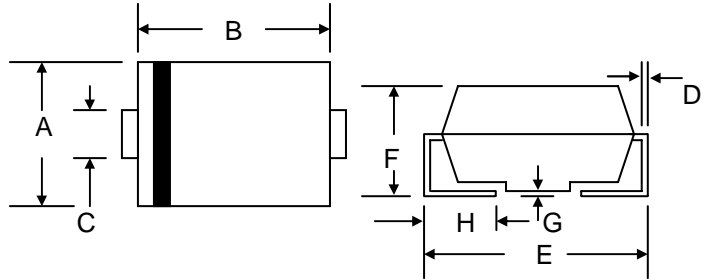

Mechanical Data

- Case: SMB/DO-214AA, Molded Plastic
- Terminals: Solder Plated, Solderable per MIL-STD-750, Method 2026
- Polarity: Cathode Band Except Bi-Directional
- Marking: Device Code
- Weight: 0.093 grams (approx.)
- **Lead Free: For RoHS / Lead Free Version, Add “-LF” Suffix to Part Number, See Page 5**

SMB/DO-214AA		
Dim	Min	Max
A	3.30	3.94
B	4.06	4.70
C	1.91	2.11
D	0.152	0.305
E	5.08	5.59
F	2.13	2.44
G	0.051	0.203
H	0.76	1.27
All Dimensions in mm		

“C” Suffix Designates Bi-directional Devices
 “A” Suffix Designates 5% Tolerance Devices
 No Suffix Designates 10% Tolerance Devices

Maximum Ratings and Electrical Characteristics @ $T_A=25^{\circ}\text{C}$ unless otherwise specified

Characteristic	Symbol	Value	Unit
Peak Pulse Power Dissipation 10/1000 μs Waveform (Note 1, 2) Figure 3	PPPM	600 Minimum	W
Peak Pulse Current on 10/1000 μs Waveform (Note 1) Figure 4	IPPM	See Table 1	A
Steady State Power Dissipation (Note 4)	$P_{M(AV)}$	5.0	W
Peak Forward Surge Current 8.3ms Single Half Sine-Wave Superimposed on Rated Load (JEDEC Method) (Note 2, 3)	I_{FSM}	100	A
Typical Thermal Resistance, Junction to Lead (Note 5)	$R_{\theta JL}$	20	$^{\circ}\text{C/W}$
Typical Thermal Resistance, Junction to Ambient (Note 5)	$R_{\theta JA}$	100	$^{\circ}\text{C/W}$
Operating and Storage Temperature Range	T_j, T_{STG}	-55 to +150	$^{\circ}\text{C}$

- Note: 1. Non-repetitive current pulse per Figure 4 and derated above $T_A = 25^{\circ}\text{C}$ per Figure 1.
 2. Mounted on 5.0mm² (0.013mm thick) land area.
 3. Measured on 8.3ms single half sine-wave or equivalent square wave, duty cycle = 4 pulses per minutes maximum.
 4. Lead temperature at 75 $^{\circ}\text{C}$.
 5. Mounted on minimum recommended pad layout.

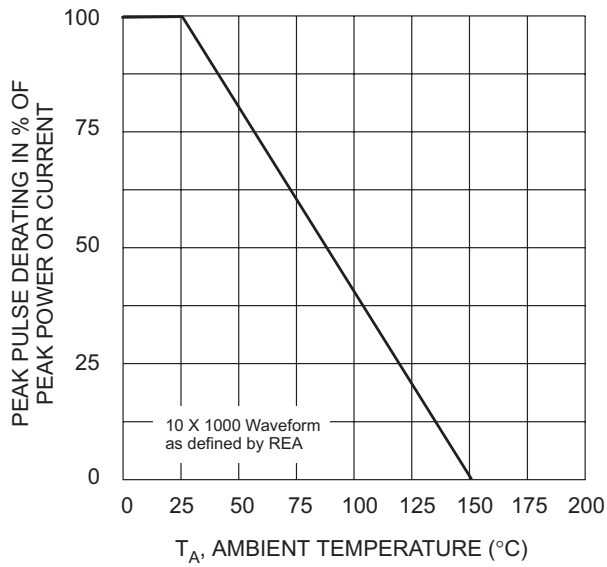

Fig. 1 Pulse Derating Curve

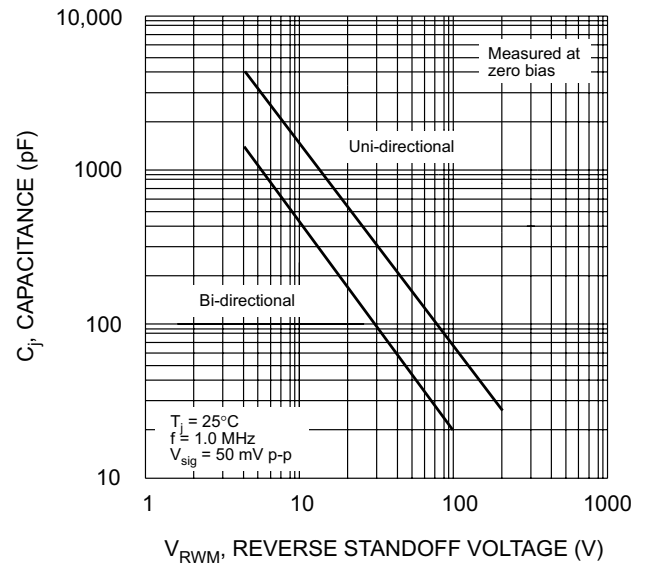

Fig. 2 Typical Junction Capacitance

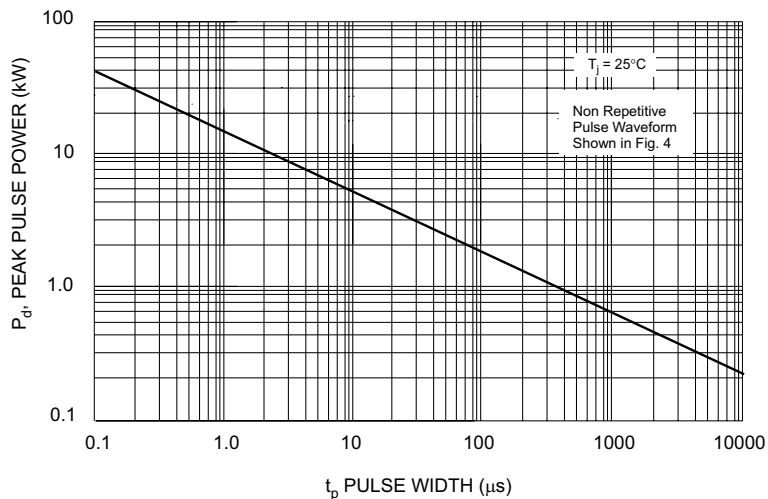

Fig. 3 Pulse Rating Curve

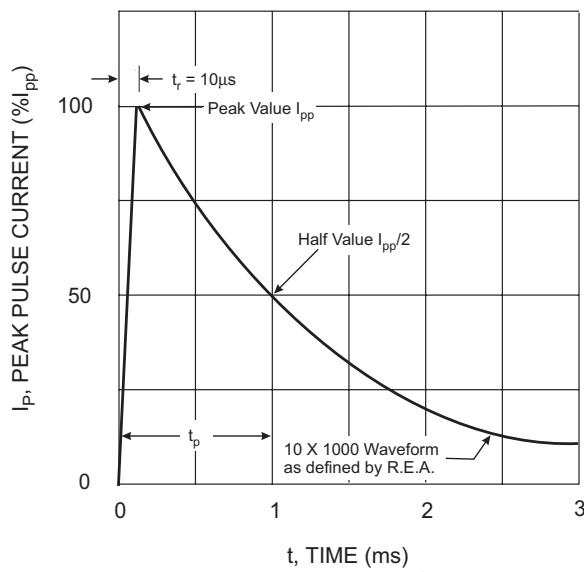

Fig. 4 Pulse Waveform

UNI-DIRECTIONAL 600 WATT SURFACE MOUNT TVS

UNI-DIRECTIONAL PART NO.	DEVICE MARKING CODE	REVERSE STAND-OFF VOLTAGE VRWM (V)	BREAKDOWN VOLTAGE VBR (V) MIN. @IT	BREAKDOWN VOLTAGE VBR (V) MAX. @IT	TEST CURRENT IT (mA)	MAXIMUM CLAMPING VOLTAGE @Ipp Vc (V)	PEAK PULSE CURRENT Ipp (A)	REVERSE LEAKAGE @VRWM IR (uA)
P6SMBJ180	PS	180.00	200.00	244.80	1	322.0	1.86	1
P6SMBJ180A	PT	180.00	200.00	220.00	1	292.0	2.06	1
P6SMBJ190	PU	190.00	211.00	258.40	1	340.0	1.76	1
P6SMBJ190A	PV	190.00	211.00	232.00	1	308.0	1.95	1
P6SMBJ200A	PX	200.00	224.00	247.00	1	324.0	1.85	1
P6SMBJ220A	QE	220.00	246.00	272.00	1	356.0	1.69	1
P6SMBJ250A	QF	250.00	279.00	309.00	1	405.0	1.48	1
P6SMBJ300A	QG	300.00	335.00	371.00	1	486.0	1.23	1
P6SMBJ350A	QH	350.00	391.00	432.00	1	567.0	1.06	1
P6SMBJ400A	QK	400.00	447.00	494.00	1	648.0	0.93	1
P6SMBJ440A	QL	440.00	492.00	543.00	1	713.0	0.84	1

BI-DIRECTIONAL 600 WATT SURFACE MOUNT TVS

BI-DIRECTIONAL PART NO.	DEVICE MARKING CODE	REVERSE STAND-OFF VOLTAGE VRWM (V)	BREAKDOWN VOLTAGE VBR (V) MIN. @IT	BREAKDOWN VOLTAGE VBR (V) MAX. @IT	TEST CURRENT IT (mA)	MAXIMUM CLAMPING VOLTAGE @Ipp Vc (V)	PEAK PULSE CURRENT Ipp (A)	REVERSE LEAKAGE @VRWM IR (uA)
P6SMBJ180C	ES	180.00	200.00	244.80	1	322.0	1.86	1
P6SMBJ180CA	ET	180.00	200.00	220.00	1	292.0	2.06	1
P6SMBJ190C	EU	190.00	211.00	258.40	1	340.0	1.76	1
P6SMBJ190CA	EV	190.00	211.00	232.00	1	308.0	1.95	1
P6SMBJ200CA	EX	200.00	224.00	247.00	1	324.0	1.85	1
P6SMBJ220CA	FE	220.00	246.00	272.00	1	356.0	1.69	1
P6SMBJ250CA	FF	250.00	279.00	309.00	1	405.0	1.48	1
P6SMBJ300CA	FG	300.00	335.00	371.00	1	486.0	1.23	1
P6SMBJ350CA	FH	350.00	391.00	432.00	1	567.0	1.06	1
P6SMBJ400CA	FK	400.00	447.00	494.00	1	648.0	0.93	1
P6SMBJ440CA	FL	440.00	492.00	543.00	1	713.0	0.84	1

MARKING INFORMATION

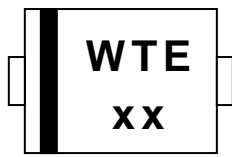

Cathode = Polarity Band Except Bi-Directional Types
 WTE = Manufacturer's Logo
 xx = Device Code, See Page 3

RECOMMENDED FOOTPRINT

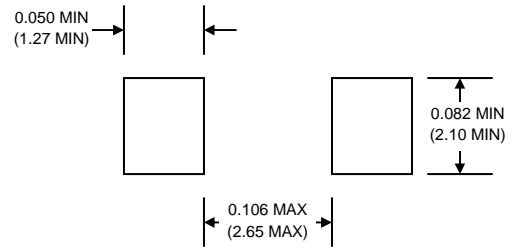

inches(mm)

PACKAGING INFORMATION

TAPE & REEL

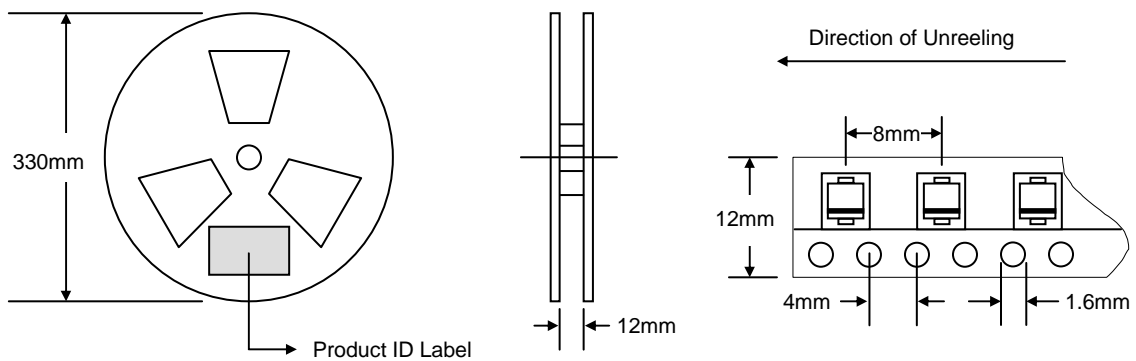

Reel Diameter (mm)	Quantity (PCS)	Inner Box Size L x W x H (mm)	Quantity (PCS)	Carton Size L x W x H (mm)	Quantity (PCS)	Approx. Gross Weight (KG)
330	3,000	340 x 337 x 45	6,000	370 x 370 x 420	48,000	14.0

Note: 1. Paper reel, white or gray color.
 2. Components are packed in accordance with EIA standard 481-1 and 481-2.

ORDERING INFORMATION

Product No.	Package Type	Shipping Quantity
P6SMBJxx-T3	SMB	3000/Tape & Reel

1. Shipping quantity given is for minimum packing quantity only. For minimum order quantity, please consult the Sales Department.
2. **To order RoHS / Lead Free version, add "-LF" suffix to part number above. For example, P6SMBJ180-T3-LF.**

Won-Top Electronics Co., Ltd (WTE) has checked all information carefully and believes it to be correct and accurate. However, WTE cannot assume any responsibility for inaccuracies. Furthermore, this information does not give the purchaser of semiconductor devices any license under patent rights to manufacturer. WTE reserves the right to change any or all information herein without further notice.

WARNING: DO NOT USE IN LIFE SUPPORT EQUIPMENT. WTE power semiconductor products are not authorized for use as critical components in life support devices or systems without the express written approval.

Won-Top Electronics Co., Ltd.

No. 44 Yu Kang North 3rd Road, Chine Chen Dist., Kaohsiung, Taiwan

Phone: 886-7-822-5408 or 886-7-822-5410

Fax: 886-7-822-5417

Email: sales@wontop.com

Internet: <http://www.wontop.com>

We power your everyday.